

INSTALLATION, USAGE, CAUTIONS IN APPLICATION OF COMPOSITE PUSH IN FITTINGS

1. WARNING

- 1.1 Except air and water (not intended for use in potable water systems), never attempt to use the composite push-in fittings for other fluids.
- 1.2 The application is prohibited where spark and fire might be occurred.
- 1.3 The application is prohibited if water temperature is above 60°C, because resin might be decomposed and damaged in water under a high temperature.
- 1.4 This kind of fittings are not designed for application where there is static charge.
- 1.5 Never apply these fittings with additional external load (bending, twist or pulling), otherwise damage or leakage will be occurred.

2. INSTALLATION

2.1 To Connect and Disconnect the Tubing

- 2.1.1 We advise you to use PNEUFLEX's high quality tubing. If you use other suppliers' tubing, the different tubing tolerance might cause leakage or incorrect connection and disconnection. You must check if tubing OD is in compliance with the specification as listed in following table.

SIZE	POLYURETHANE TUBE	NYLON TUBE
Φ3mm	±0.10	±0.08
Φ4mm	±0.10	±0.08
Φ6mm	±0.12	±0.10
Φ8mm	±0.12	±0.10
Φ10mm	±0.15	±0.12
Φ12mm	±0.15	±0.12
Φ14mm	±0.15	±0.12
Φ16mm	±0.15	±0.12

SIZE	POLYURETHANE TUBE	NYLON TUBE
Φ1/8"	±0.10	±0.08
Φ5/32"	±0.10	±0.08
Φ3/16"	±0.12	±0.10
Φ1/4"	±0.12	±0.10
Φ5/16"	±0.12	±0.10
Φ3/8"	±0.15	±0.12
Φ1/2"	±0.15	±0.12
Φ5/8"	±0.15	±0.12

2.1.2 Always check the end of tubing for a right angle cutting. Make sure that there is no any damage or scratch on the outer surface of tubing (see 2.1.2 ①). Please refer to following instruction in connection of tubing. When you insert the air tubing into fitting, you will have two-step feeling. Section One (see 2.1.2 ②) is locking claw while Section Two (2.1.2 ③) is sealing ring. You must insert the tube into Section Two to ensure that the tubing is inserted fully to the end of the fitting. Finally, pull the tube gently to make sure the tubing isn't released.

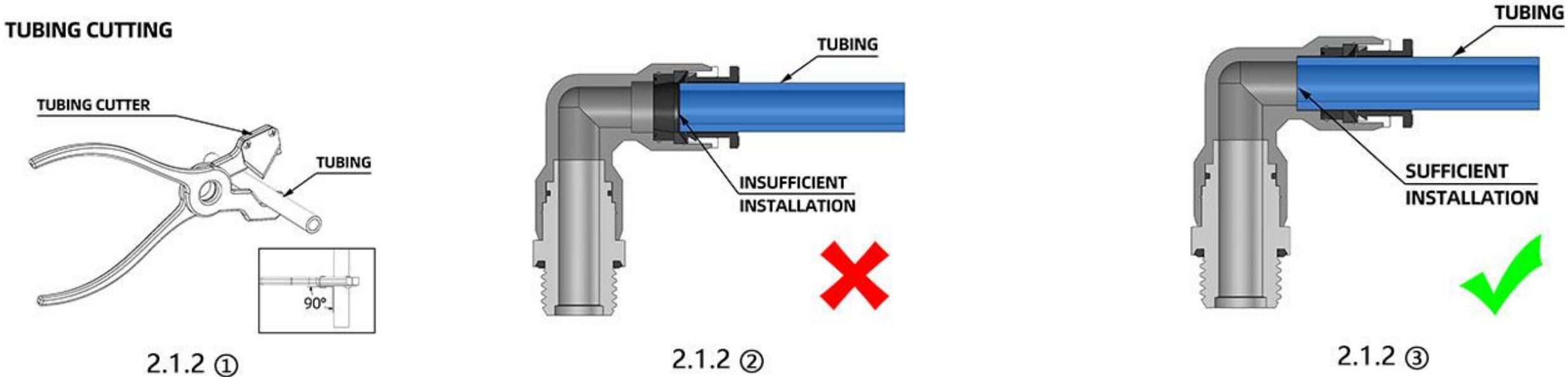

2.1.3 The minimum insertion length of tubing is listed in the dimensions table of each part, however, the tubing length tolerance is necessary in practice.

2.1.4 Pulling or twisting the tubing excessively may damage the fitting. For a mount guide, see the table below:

MINIMUM BENDING RADIUS

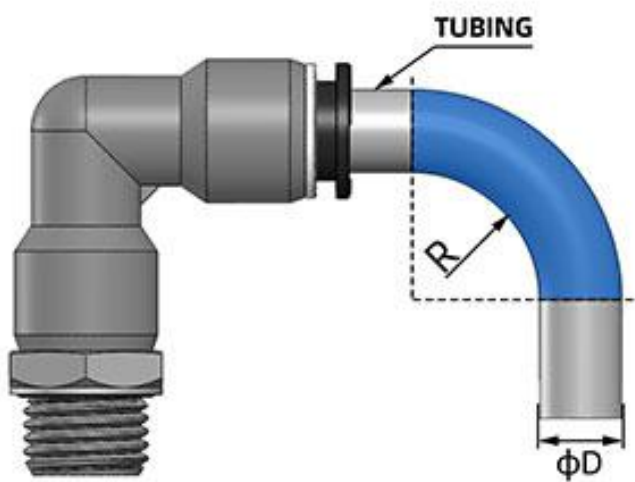

MINIMUM BENDING RADIUS (R) OF THE TUBING O.D (mm)

Tubing O.D (φ)	φ3	φ4	φ6	φ8	φ10	φ12	φ14	φ16
Minimum Bending Radius (R)	15	20	30	50	80	150	230	350

MINIMUM BENDING RADIUS (R) OF THE TUBING O.D (mm)

Tubing O.D (φ)	φ1/8"	φ5/32"	φ3/16"	φ1/4"	φ5/16"	φ3/8"	φ1/2"	φ5/8"
Minimum Bending Radius (R)	15	20	30	30	50	80	150	350

2.1.5 Before removing the tubing from the fitting, make sure that internal pressure of tube is zero. For disconnection of tubing, always press sleeve heavily and then pull out tubing. If sleeve is not pressed with enough force, it is hard to pull out tubing and external surface scratch might be resulted by locking claw, which would cause leakage. Don't swing or rotate tubing in disconnection otherwise groove might be resulted on the tubing surface by locking claw to prevent tubing from pulling.

PNEUFLEX's fitting sleeve is designed as an oval shape, which is convenient in connection and disconnection. However, round sleeve is also available to meet any customer special demand if the customer product has limited space for oval sleeve.

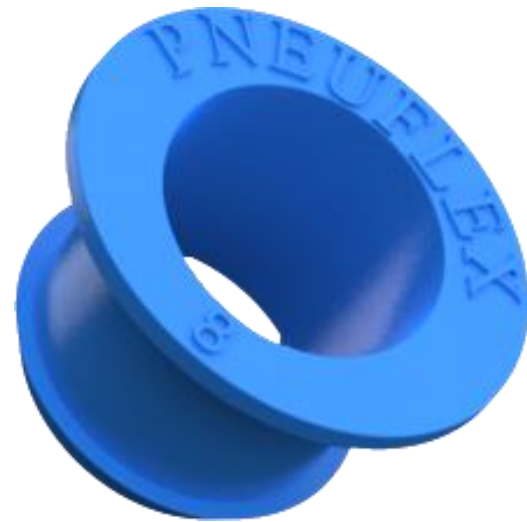

CONNECTING

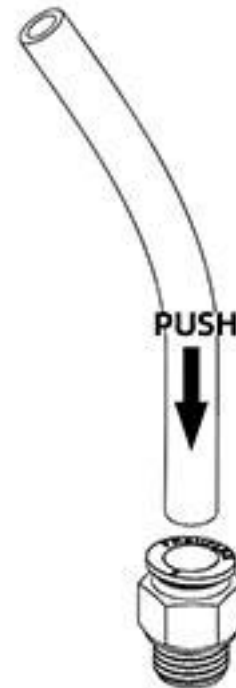

DISCONNECTING

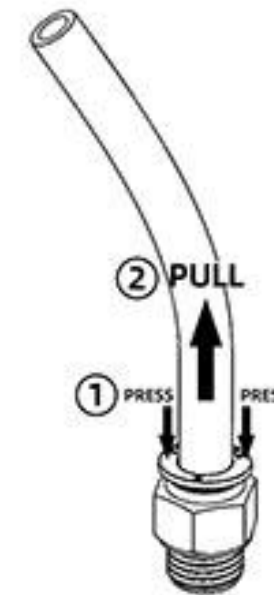

2.2 Connection Thread Tightening Method and Loosen Fittings from Equipment Body

2.2.1 Always use proper tool to tighten external hexagonal and internal hexagonal fitting as show in the pictures below. Always apply recommended torque on screws otherwise extra torque might damage thread and cause air leakage while insufficient torque might cause loose screws and air leakage. After screws are tightened, you may adjust the direction of tubing. If it is hard in adjustment, you may apply recommended torque to turn screw to adjust direction of tubing, please refer to the range of the torque showing in below table (Page5).

OUTER HEXAGON TIGHTENING

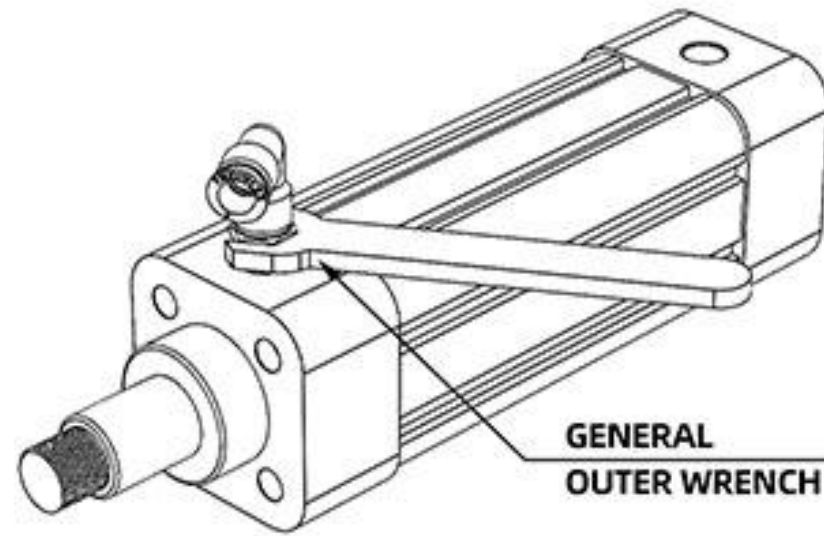

OUTER HEXAGON TIGHTENING

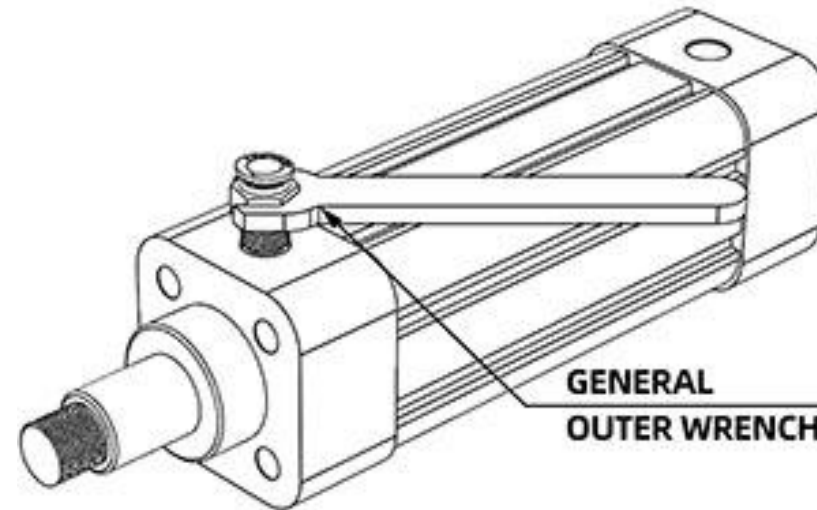

INNER HEXAGON TIGHTENING

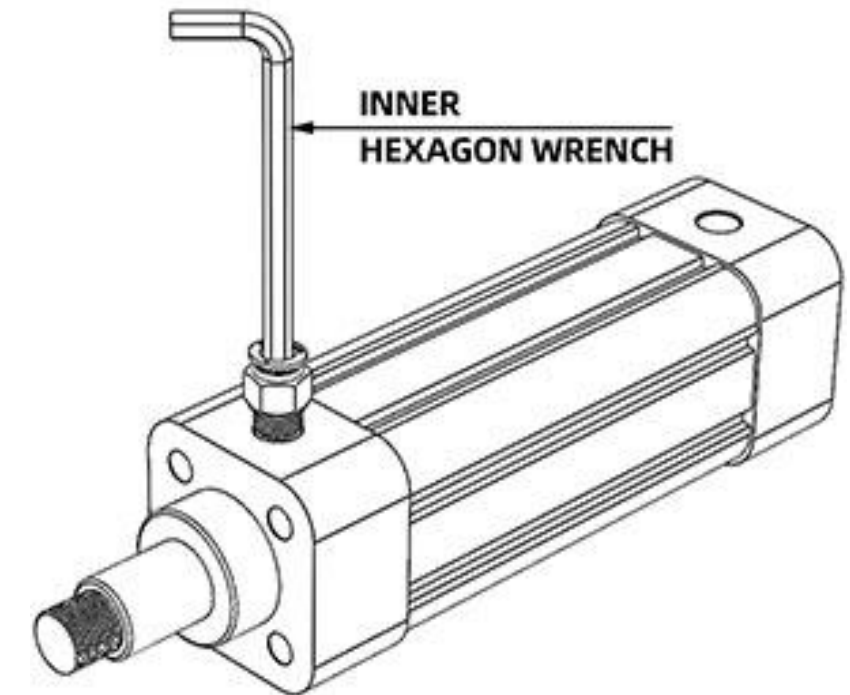

2.2.2 When loosen the fittings from equipment body, please use proper tool. After disconnecting, please clean the thread glue on equipment, otherwise the remaining thread glue will enter the equipment and cause damage.

RECOMMENDED TORQUE FOR DIFFERENT THREAD SPECIFICATION		
Thread Type	Thread Specification	Torque (kgf.cm)
Metric Thread	M3	7
	M5	15-19
	M6	20-27
R/Rc Thread	R/Rc 1/8	70-90
	R/Rc 1/4	120-140
	R/Rc 3/8	220-240
	R/Rc 1/2	280-300
UNF (Unified)	NO. 10-32 UNF	15-19
NPT Thread	1/16 NPT	70-90
	1/8 NPT	70-90
	1/4 NPT	120-140
	3/8 NPT	220-240
	1/2 NPT	280-300